

ALL DIMENSIONS IN METERS UNLESS NOTED OTHERWISE

# AERODROME OBSTACLE CHART - ICAO TYPE A - OPERATING LIMITATIONS

REGINA INTERNATIONAL AIRPORT  
SASKATCHEWAN

## RUNWAY 13-31

### DECLARED DISTANCES (IN FEET)

RWY 13		RWY 31
7901	TAKE-OFF RUN AVAILABLE	7901
8885	TAKE-OFF DISTANCE AVAILABLE	8885
7901	ACCELERATE-STOP DISTANCE AVAILABLE	7901
7901	LANDING DISTANCE AVAILABLE	7901

MAGNETIC VARIATION 8°45.36' (2018)  
ANNUAL CHANGE 00°7.3' W/YEAR  
MAGNETIC BEARING OF RUNWAY 128°57'50"  
TRUE BEARING OF RUNWAY 137°43'21"

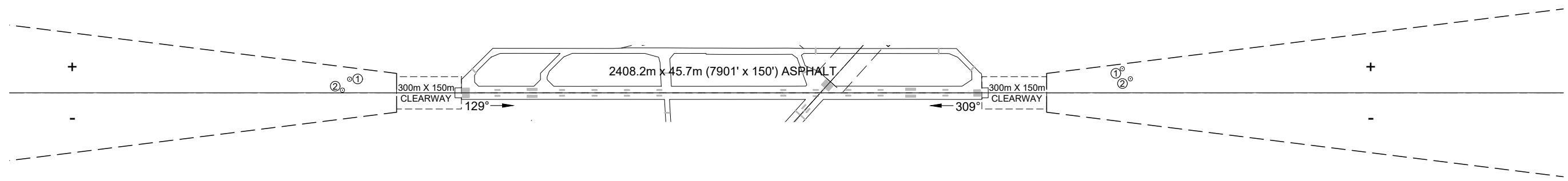

NUMBER	OBSTACLE	HEIGHT (MSL)	GROUND DISTANCE	GROUND DISTANCE OFF CENTERLINE
①	POLE	584.1m	517.4m	63.3m
②	POLE	584.8m	550.4m	12.4m

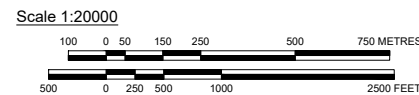

NUMBER	OBSTACLE	HEIGHT (MSL)	GROUND DISTANCE	GROUND DISTANCE OFF CENTERLINE
①	POLE	588.0m	649.4m	111.5m
②	POLE	588.9m	687.0m	64.7m

LEGEND		
	PLAN	PROFILE
IDENTIFICATION NUMBER	①	↑
TREE OR SHRUB	*	↑
LIGHT POLE / POWER POLE	○	↑
BUILDING OR LARGE STRUCTURE	■	①
CLEARWAY	---	---

ALL DIMENSIONS IN METERS UNLESS NOTED OTHERWISE

# AERODROME OBSTACLE CHART - ICAO TYPE A - OPERATING LIMITATIONS

REGINA INTERNATIONAL AIRPORT  
SASKATCHEWAN

MAGNETIC VARIATION 8°45.72' (2018)  
ANNUAL CHANGE 00°7.3' W/YEAR  
MAGNETIC BEARING OF RUNWAY 80°57'20"  
TRUE BEARING OF RUNWAY 89°43'3"

## RUNWAY 08-26

DECLARED DISTANCES (IN FEET)		
RWY 08		RWY 26
6200	TAKE-OFF RUN AVAILABLE	6200
7184	TAKE-OFF DISTANCE AVAILABLE	7184
6200	ACCELERATE-STOP DISTANCE AVAILABLE	6200
6200	LANDING DISTANCE AVAILABLE	6200

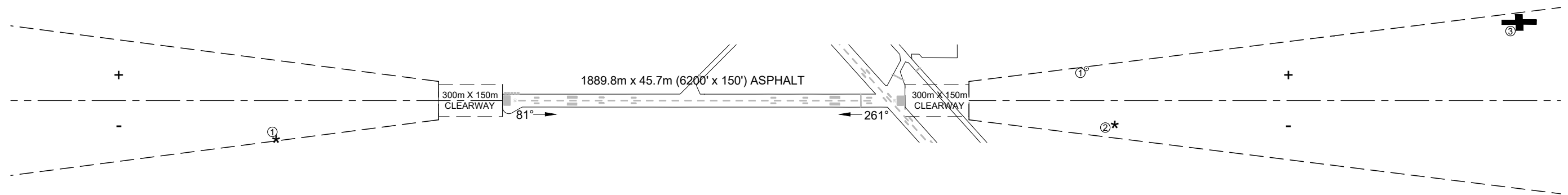
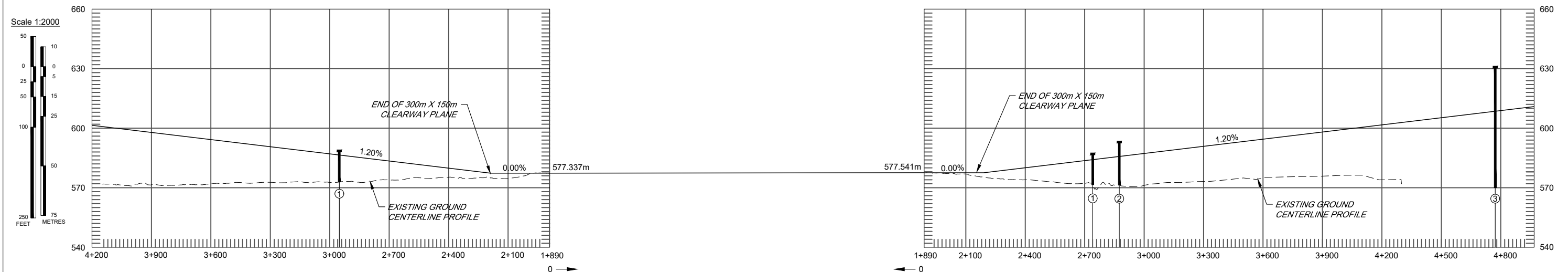

NUMBER	OBSTACLE	HEIGHT (MSL)	GROUND DISTANCE	GROUND DISTANCE OFF CENTERLINE
①	TREE	588.6m	1058.7m	-182.9m

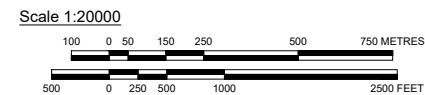

NUMBER	OBSTACLE	HEIGHT (MSL)	GROUND DISTANCE	GROUND DISTANCE OFF CENTERLINE
①	POLE	587.0m	850.9m	149.3m
②	TREE	593.0m	984.9m	-115.6m
③	BUILDING	630.8m	2882.3m	371.1m

LEGEND		
	PLAN	PROFILE
IDENTIFICATION NUMBER	①	↑
TREE OR SHRUB	*	↑
LIGHT POLE / POWER POLE	○	↑
BUILDING OR LARGE STRUCTURE	■	⊕
CLEARWAY	---	---